

# Dragon

Designed by Jo Nakashima

<http://jonakashima.com.br>

<http://youtube.com/jonakashima>

Date: 20/Feb/2015

Difficulty Level: low intermediate

Time to fold it: 30 minutes

Video: <http://youtu.be/kUsxMXwCW8A>

Paper: 20cm x 20cm

- Standard paper
- Tissue foil
- Wet folding

1.

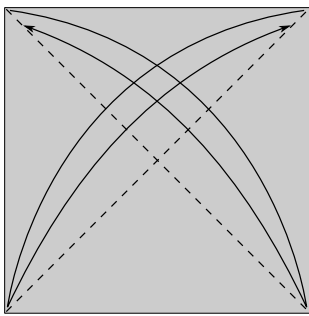

2.

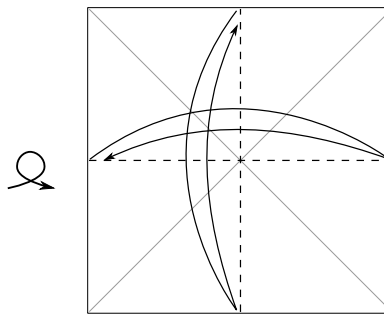

3.

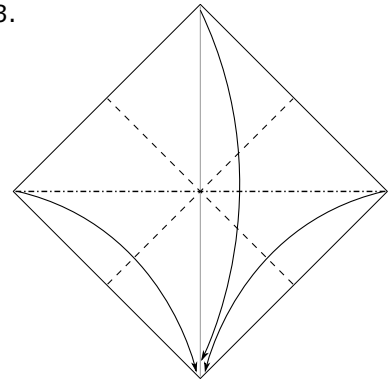

4.

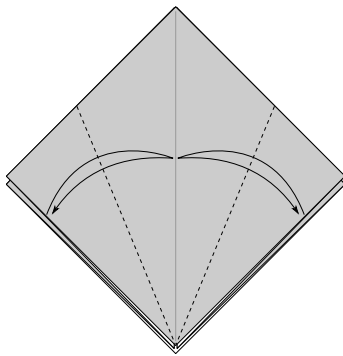

5.

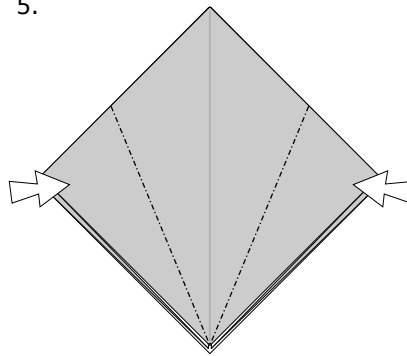

6.

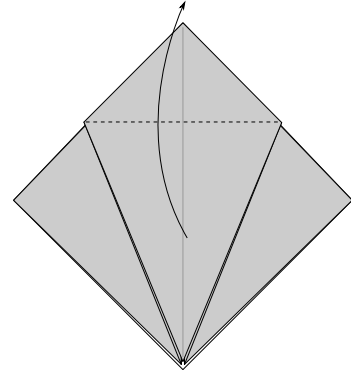

7.

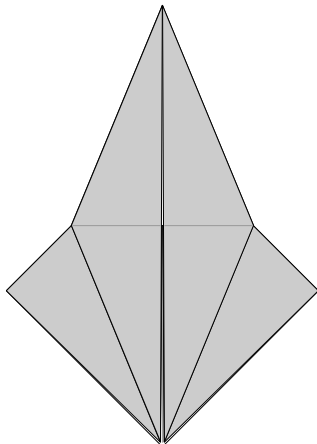

8.

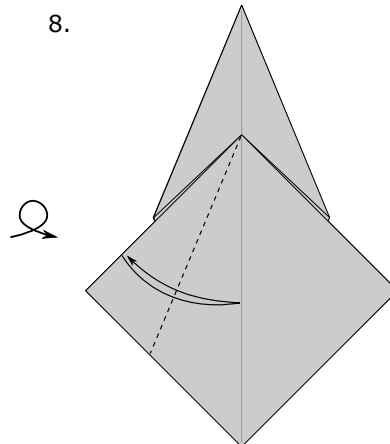

9.

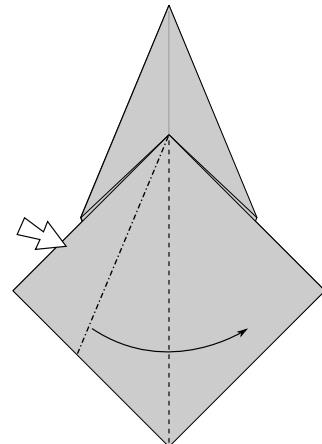

10.

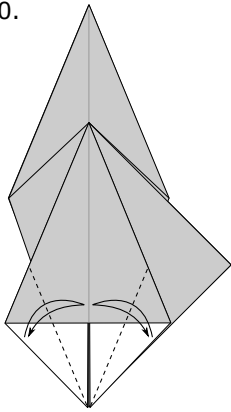

11.

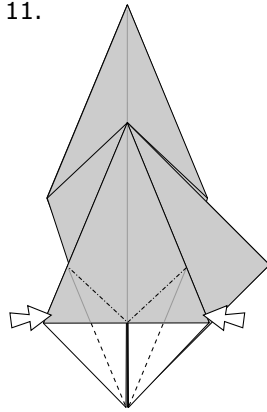

12.

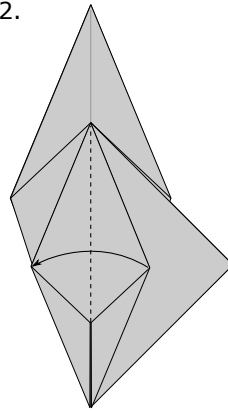

13.

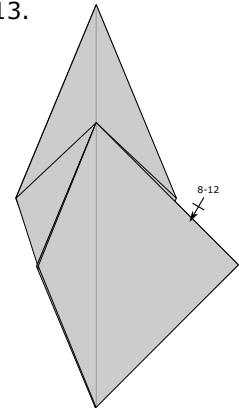

14.

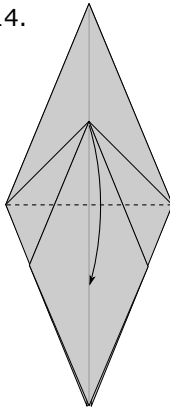

15.

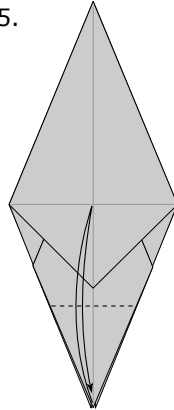

16.

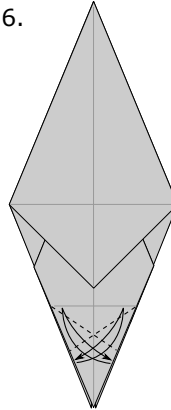

17.

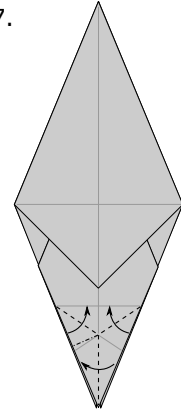

18.

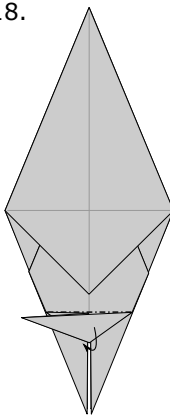

19.

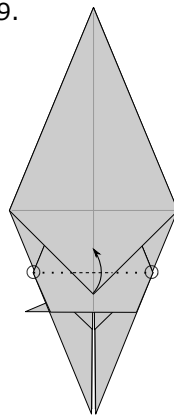

20.

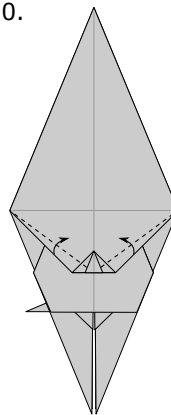

21.

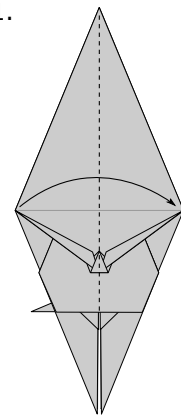

22.

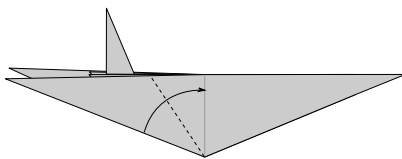

23.

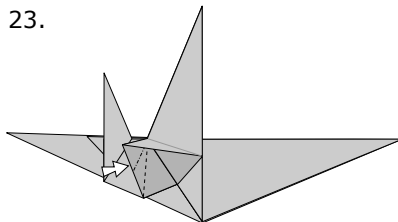

24.

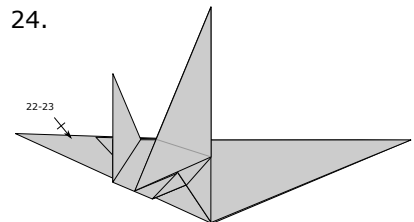

25.

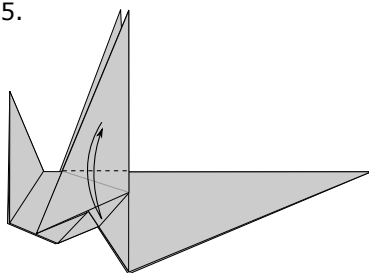

26.

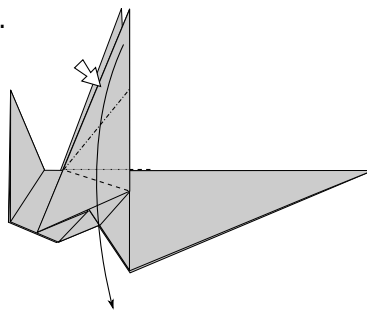

27.

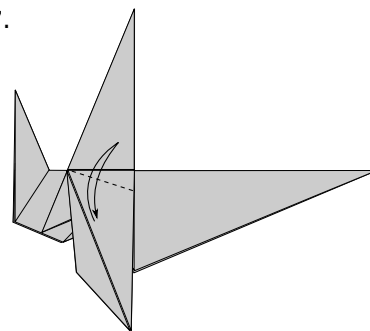

28.

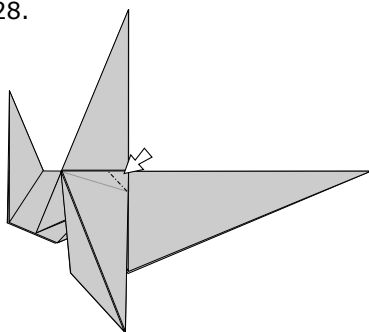

29.

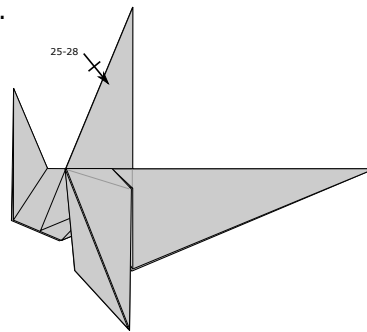

30.

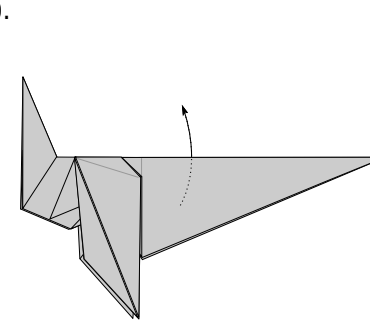

31.

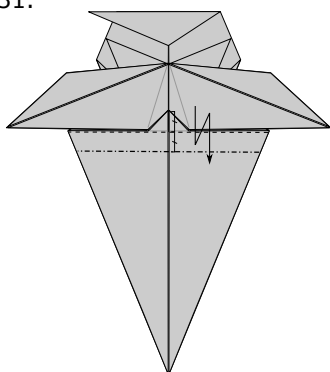

32.

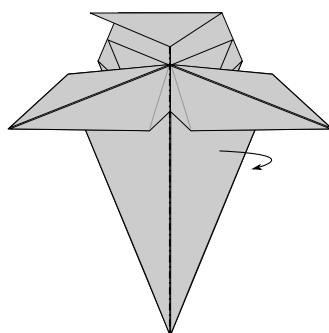

33.

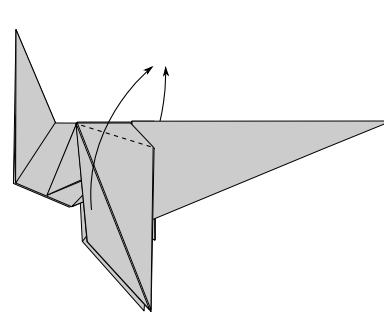

Pleat-fold under the wings

34.

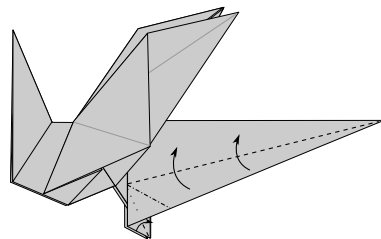

35.

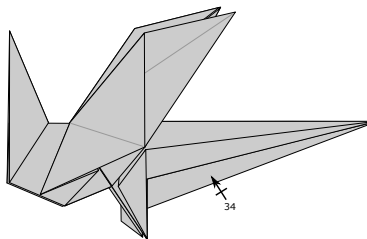

36.

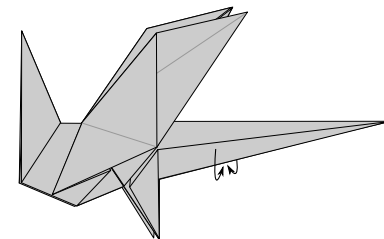

37.

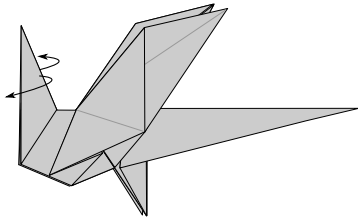

38.

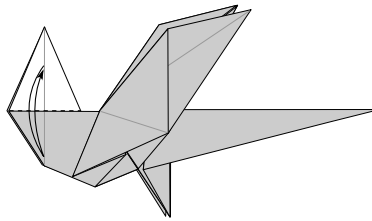

39.

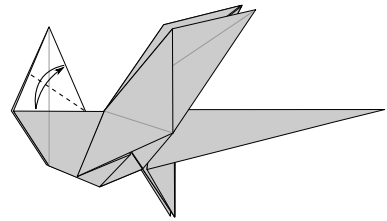

Release the trapped layers

40.

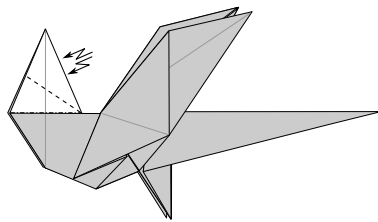

41.

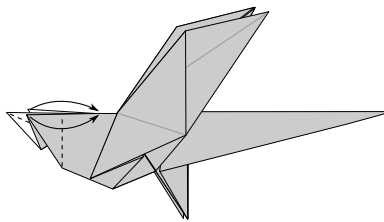

42.

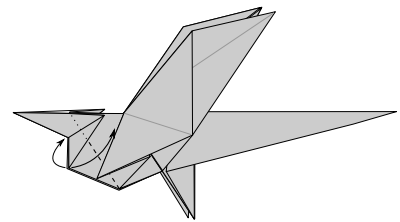

43.

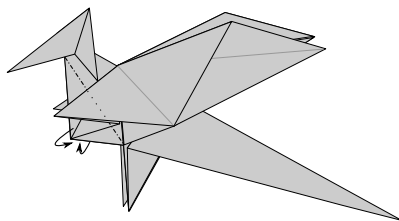

44.

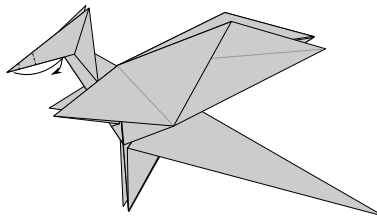

45.

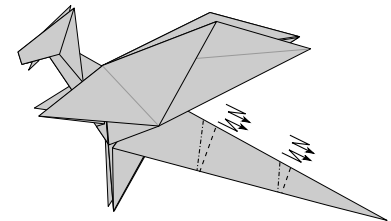

46.

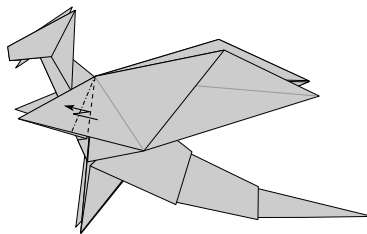

47.

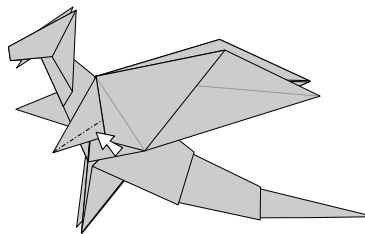

48.

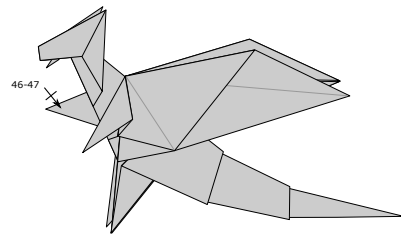

49.

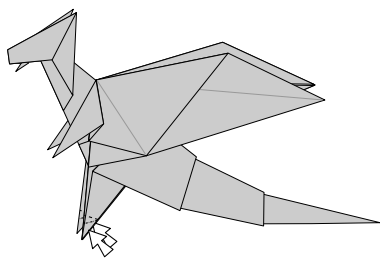

50.

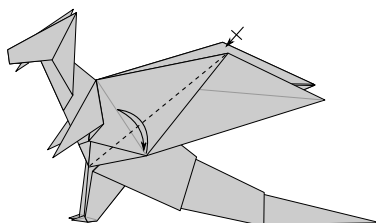

51.

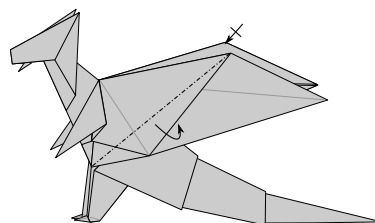

52.

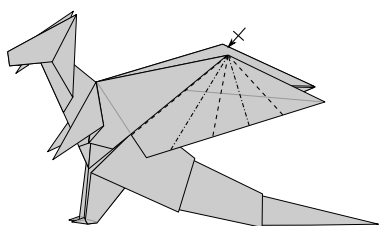

53.

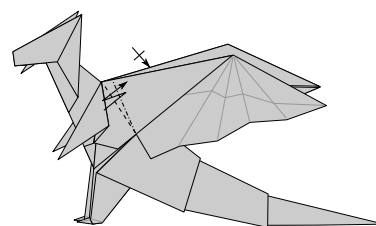

54.

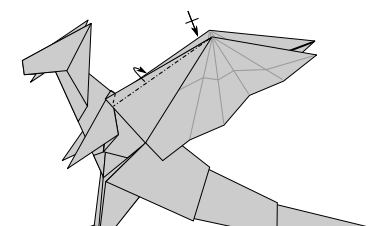

55.

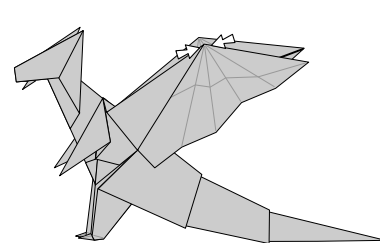

56.

